

SOLOBLOC

HINGED 'LIFT ASSISTED,
SINGLE PERSON OPERATION' HSE COMPLIANT

CPH8 MULTIPLE LEAF

All Solobloc units are post galvanised in excess of BS EN 1461. Post Galvanised coating thickness is available in 3 grades of finish to suit the specific project geographical location. Solobloc units should be designed to cater for their intended application and should last the life of the project. See chart on page 77 for the various grades of corrosion protection required to meet the designers obligations on Whole Life Costing for the project.

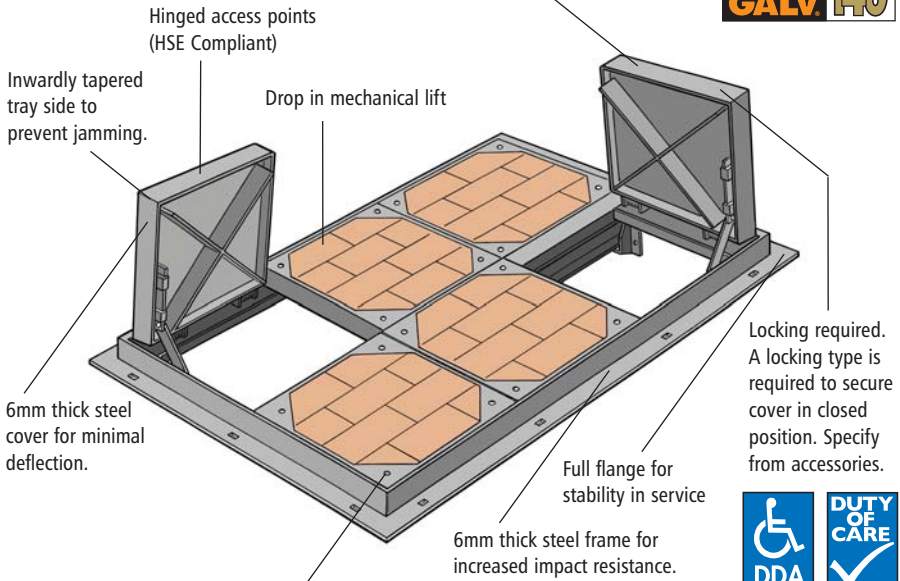

DDA Compliant Lifting points.
'Lift assisted HSE manual handling compliant for single person operation'



Compliant products



Jones of Oswestry provides RIBA approved CPD support for designers and architects in the subject of true sustainable design. For further details email marketingsupport@jonesofoswestry.com



ALL TECHNICAL DETAILS ARE COPYRIGHT, AND MUST NOT BE REPRODUCED WITHOUT PRIOR CONSENT

SOLOBLOC

CPH8 BEAM DETAILS

GENERAL TECHNICAL DETAIL, COMPOSITION AND MANUFACTURE

STANDARD PRODUCT FEATURES

- Beams are removable unless stated otherwise
- Hot dip galvanised in-house as standard
- Beams have lifting points to each end for safe mechanical removal
- Sealing bars are integral part of beam, on sealed covers

MATERIALS

All removable beams are hot rolled structural steel universal beams to BS EN 10025/S275, hot dip galvanised after manufacture to BS EN ISO 1461 as standard.

Each removable beam is selected for its loading, and its length cut to suit the clear opening span. It is fully supported at each end by brackets as detailed on pages 74 & 75.

TECHNICAL DETAILS

Multiple leaf access cover and frame units can be manufactured to suit any required internal clear opening size and to accept loadings in accordance with BS EN 124 classes A15, B125 and C250. The use of removable support beams enables this and allows us to sub-divide the assembly into manageable sections for ease of removal and entry, whether

by a single operative or by mechanical means. Asymmetric units can also be designed for situations where in situ plant or machinery precludes the use of a standard assembly.

A full Technical Advisory Service is always available to make recommendations based on our wide experience in this specialised field. If a complicated access chamber pit layout is required a fully dimensional plan/section detail should be supplied. Individual working, site layout, drawings are provided for multiple leaf covers requiring support beams upon receipt of order.

BEAM SIZE DETAILS FOR MULTIPLE LEAF ASSEMBLIES

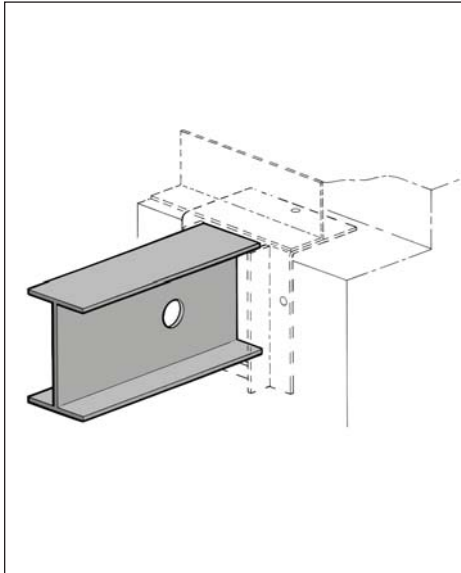

BEAM SIZE IDENTIFICATION

(for beam sizes refer to chart opposite)

CLEAR OPENING SPAN	A15 	B125 	C250
651-900	-	*	*
901-1200	-	*	B
1201-1500	*	A	B
1501-2000	A	B	B
2001-2500	A	B	C
2501-3000	A	C	D
3001 →	contact our Technical Department		

* support attached to cover max 200 deep from floor level

ALL TECHNICAL DETAILS ARE COPYRIGHT, AND MUST NOT BE REPRODUCED WITHOUT PRIOR CONSENT

SOLOBLOC CPH8 BEAM DETAILS

PRODUCTS AND INFORMATION CAN BE AMENDED WITHOUT PRIOR CONSENT TO MAINTAIN THE COMPANY POLICY OF CONTINUED IMPROVEMENT

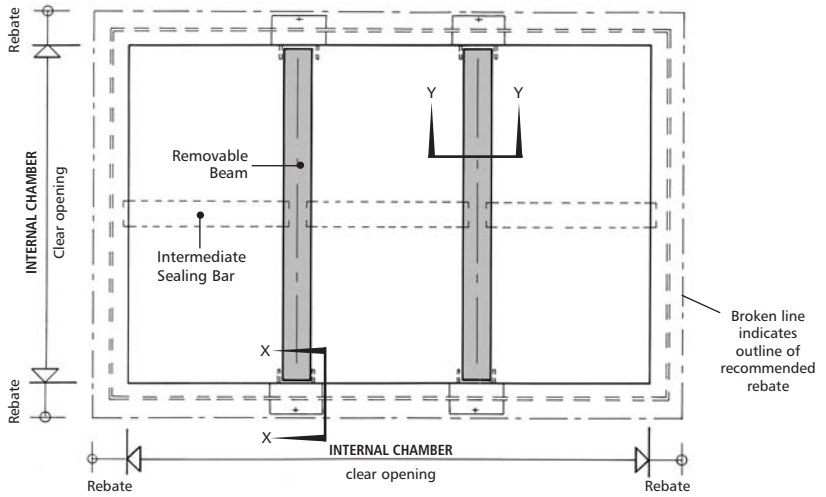

Note: On sealed covers - intermediate sealing bars are fitted.

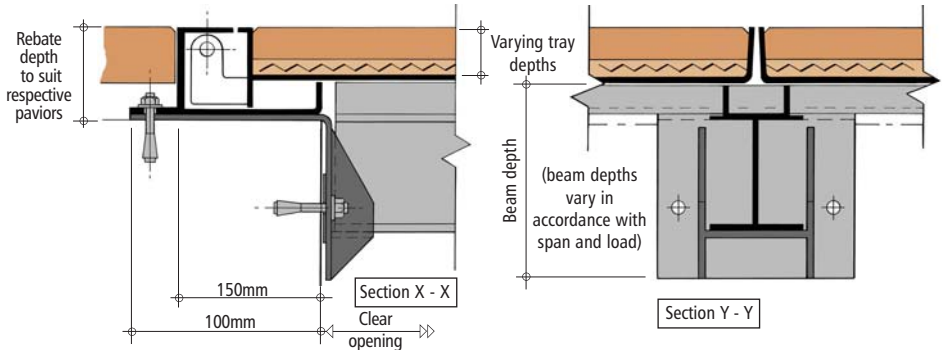

Note: Beams can span either short dimension or long dimension depending on operational requirement.

BEAM SIZE	UNIVERSAL BEAM SIZE (mm)
A	152 x 89 x 16 Kg/m
B	203 x 133 x 30 Kg/m
C	254 x 146 x 43 Kg/m
D	305 x 127 x 48 Kg/m

SOLOBLOC

CPH8 BEAM BRACKET DETAILS

GENERAL TECHNICAL DETAIL, COMPOSITION AND MANUFACTURE

STANDARD PRODUCT FEATURES

All brackets are fabricated from structural steel plate and hot dip galvanised after manufacture to BS EN ISO 1461 as standard.

BRACKET DESIGN

The brackets have been designed to suit standard beams A to D shown on page 73. They have been designed and tested to suit worst case scenarios. All brackets are welded to form an integral part of the frame.

Brackets have a 5mm clearance from chamber clear opening to allow for concrete deviation. Any space between

bracket and chamber wall must be shim-packed before tightening anchor bolts.

SLAB DESIGN

The following bracket design loads are shown to assist with slab design.

Maximum considered vertical loads through beam carrier brackets on multiple units:-

Note: A Class Load Considered = 10Kn

B Class Load Considered = 75Kn

C Class Load Considered = 115Kn

Twin Wheel Load is considered for spans of 2000mm and above



Live load factor of safety = 1.6 is used. (i.e. included in figures below)

SPECIAL BRACKETS

Special brackets can be designed and manufactured to suit site and/or design requirements such as: brick chambers, steel reinforcement position, restricted slab thickness or special beam requirement.

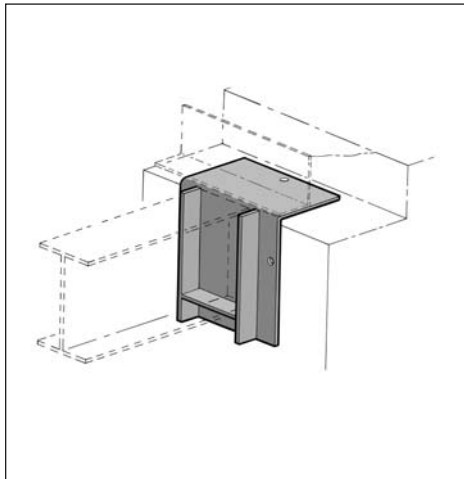
BEAM BRACKET DETAILS FOR MULTIPLE LEAF ASSEMBLIES



MAXIMUM BRACKET LOAD			
BEAM SIZE AND CORRESPONDING BRACKET	A15 	B125 	C250 
152 x 89 x 16 Beam Bracket No.1	184kn	184kn	N/A
203 x 133 x 30 Beam Bracket No.2	N/A	184kn	276kn
254 x 146 x 43 Beam Bracket No.3	N/A	184kn	276kn
305 x 127 x 48 Beam Bracket No.4	N/A	N/A	276kn

ALL TECHNICAL DETAILS ARE COPYRIGHT, AND MUST NOT BE REPRODUCED WITHOUT PRIOR CONSENT

SOLOBLOC

CPH8 BEAM BRACKET DETAILS

BEAM BRACKET NO. 1

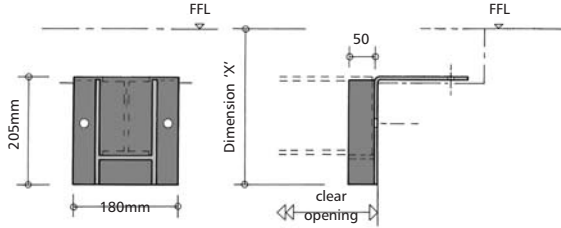

BEAM BRACKET NO. 2

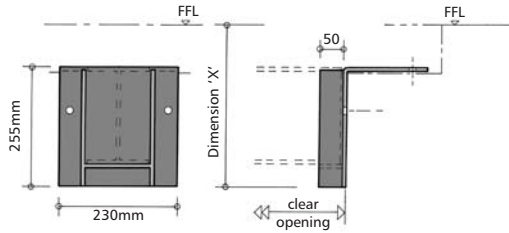

BEAM BRACKET NO. 3

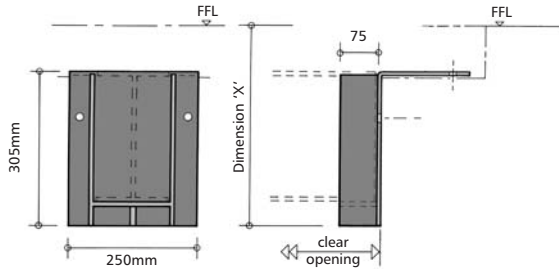

BEAM BRACKET NO. 4

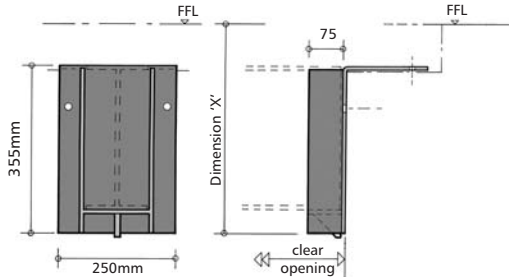



Please contact our technical department for clarification of dimension 'X'.

PRODUCTS AND INFORMATION CAN BE AMENDED WITHOUT PRIOR CONSENT TO MAINTAIN THE COMPANY POLICY OF CONTINUED IMPROVEMENT

LOAD CLASSES, BS EN 124

EUROPEAN STANDARD FOR ACCESS COVERS

LOAD CLASSES	TEST LOAD	SUGGESTED AREAS OF USAGE	SPECIFYING CODE
 A15	15kN (1.5 Tonne)	Pedestrian and Cycle Areas	/A
		Recommended S.M.W.L. Not exceeding 1 Tonne	
 B125	125kN (12.5 Tonne)	Pavement, Pedestrian Zones, Car Parks & Verges	/B
		Recommended S.M.W.L. Not exceeding 6 Tonne	
C250	250kN	Contact our technical support team for advice on exceptionally heavy vehicled areas.	/C
D400	400kN		/SD

ALTHOUGH NOT COMPLYING WITH BS EN 124, OTHER INTERMEDIATE LOAD CLASSES ARE AVAILABLE, CONSULT OUR TECHNICAL DEPARTMENT

SECTIONAL DETAILS

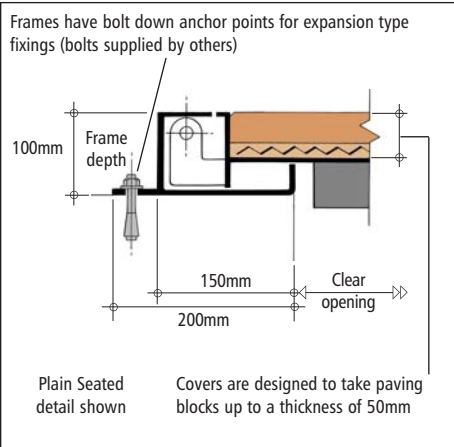

DIMENSIONS

Installation dimensions, based around chamber clear openings are as shown. Although example clear opening sizes are tabulated, SOLOBLOC is available in any size to suit specific project requirements within the design scope of HSE compliance. Tray depth caters for 50mm or 65mm thickness of slab or pavior infill, please specify depth of block infill required.

ACCESSORY SUFFIXES

To specify add the following suffixes to the professional specification code

- A1R - Single Rubber Seating Seal
- A4 - Ventilated
- B5 - Hasp and staple c/w hinged cover plate
- H1 - Service Identification (please specify)
- L8 - Internal fall protection
- X - Grade 304 Stainless Steel Construction
- Y - Grade 316 Stainless Steel Construction

DESIGN SCOPE

Solobloc covers maybe available for blocks greater than 65mm deep. The internal clear opening size and load class required will influence the exact infill cover depth available. Please contact our technical support team for advice on techadvice@jonesofoswestry.com

ALL TECHNICAL DETAILS ARE COPYRIGHT, AND MUST NOT BE REPRODUCED WITHOUT PRIOR CONSENT

SOLOBLOC CPH8 MULTIPLE LEAF

FINISHES

How to use the Longevity Table

1. Locate your site on the Millennium map (E.g. Leeds - West Yorkshire)
2. Match the corrosion category square colour to the key (Leeds = 3 light blue)
3. Read down from Product Design Life to establish required minimum life i.e. 25 years.

4. Once minimum Product Design Life has been established, (20,25 or 30 years) cross reference with your site location category (1,2,3,4 or 5) to determine your required Duragalv finish. (Duragalv 100)
5. At the end of the specifying code DG100 needs to be added.

Coating suffix specifying codes:

Duragalv70 = DG70
Duragalv100 = DG100
Duragalv140 = DG140

Fabricated mild steel products, Hot-Dip Galvanised after manufacture = GALVANISED LONGEVITY TABLE					
Rate of corrosion of zinc (in microns per annum).	2.5	3	3.5	4	4.5
See Millennium Map for your site location or visit www.hdg.org.uk/map/index.htm	1	2	3	4	5
PRODUCT DESIGN LIFE					
20 YEARS Generally less than the normal minimum design life for product in public domain - UNACCEPTABLE WHOLE LIFE COSTING RETURN PERIOD	DURA GALV 70	DURA GALV 70	DURA GALV 70	DURA GALV 100	DURA GALV 100
25 YEARS Normal minimum design life for product in public domain - ACCEPTABLE WHOLE LIFE COSTING RETURN PERIOD	DURA GALV 70	DURA GALV 100	DURA GALV 100	DURA GALV 100	DURA GALV 140
30 YEARS Enhanced design life for product in public domain - PREFERRED WHOLE LIFE COSTING RETURN PERIOD	DURA GALV 100	DURA GALV 100	DURA GALV 140	DURA GALV 140	DURA GALV 140

Jones of Oswestry provide an extensive on-line support service. Simply attach your drawings or list your queries to techadvice@jonesofoswetry.com and one of our engineers will guide you to the most suitable solution.

HOW TO SPECIFY

PROGRESSIONAL EXAMPLE FOR SPECIFYING						
Ref DESCRIPTION	PRODUCT TYPE	CLEAR OPENING	LOAD CLASS	BLOCK INFILL DEPTH	ACCESSORY SUFFIX	FINISHED COATING
DETAIL	(SOLOBLOC MULTIPLE)	(2500mm x 1200mm)	(B125)	(65mm)	(SINGLE SEAL)	(SEE LONGEVITY TABLE)
PRODUCT Ref	CPH8	250-120	B	65	A1	DG100
THE ABOVE EQUALS FULL SPECIFYING CODE OF = CPH8/250-120/B/65/A1/DG100						

WHITTINGTON ROAD, OSWESTRY,
SHROPSHIRE, SY11 1HZ
TEL: 01691 653251
FAX: 01691 658222
EMAIL: techadvice@jonesofoswetry.com

JONES
OF OSWESTRY

SECTION 1 PAGE 77

PRODUCTS AND INFORMATION CAN BE AMENDED WITHOUT PRIOR CONSENT TO MAINTAIN THE COMPANY POLICY OF CONTINUED IMPROVEMENT

L07/00